



Main

Range of product	Zelio Relay
Product or component type	Solid state relay
Provided accessory	Thermal pad
Device short name	SSP1
Mounting support	Panel
Number of phases	1 phase
Contacts type and configuration	1 NO
[In] rated current	10 A
Solid state output type	Zero voltage switching SCR output

Complementary

[Uc] control circuit voltage	90...280 V AC
Minimum switching voltage	90 V AC turn-on
Maximum switching voltage	10 V AC turn-off
Response time	30 ms turn-off 25 ms turn-on
Input current	5...10 mA
Output voltage	24...300 V AC
Load current	0.15...10 A
Transient overvoltage	600 V
Surge current	≤ 120 A for 16.6 ms
Maximum I ² t for fusing	60 A ² .s for 8.33 ms at 60 Hz half cycle 66 A ² .s for 10 ms at 50 Hz half cycle
Co-ordination type	Type 1 - 13 A miniature circuit breaker (MCB) - curve B Type 2 - 10 A miniature circuit breaker (MCB) - curve B
Leakage current	≤ 1 mA off-state
Voltage drop	1.15 V on-state

Disclaimer: This documentation is not intended as a substitute for and is not to be used for determining suitability or reliability of these products for specific user applications

DV/Dt	500 V/ μ s off-state at maximum voltage
Power factor	0.5 with maximum load
Motor controller rating	0.5 hp 120 V AC 1 hp 240 V AC
Insulation resistance	1000 MOhm at 500 V DC
Maximum capacitance	8 pF for input/output
Dielectric strength	4 kV AC for input/output 4 kV AC for input or output to case
[Uimp] rated impulse withstand voltage	6 kV output to case 6 kV input to output
Tightening torque	1.5...1.7 N.m for input 2...2.2 N.m for output
Connections - terminals	Forked type tag connectors : 9.2 x 4 mm for input Ring lugs : 9.2 x 4 mm for input Forked type tag connectors : 11.7 x 4.5 mm for output Ring lugs : 11.7 x 4.5 mm for output Screw terminals : 0.2...3.3 mm ² , (AWG 24...AWG 12) with cable end for input Screw terminals : 0.5...5.26 mm ² , (AWG 20...AWG 10) with cable end for output Screw terminals : 0.2...3.3 mm ² , (AWG 24...AWG 12) without cable end for input Screw terminals : 0.5...8.26 mm ² , (AWG 20...AWG 8) without cable end for output
Thermal resistance	1.03 °C/W junction to case
Thermal pad impedance	0.48 °C-in ² /W at 25 psi
LED indicator	LED, green for input
IP degree of protection	IP20
Safety reliability data	MTTFd = 1875.9 years B10d = 1731395
Product weight	89.2 g

Environment

Ambient air temperature for operation	-40...80 °C
Ambient air temperature for storage	-40...125 °C
Pollution degree	2
Overvoltage category	III
Product certifications	CE CSA RoHS UL REACH EAC
Marking	CE CSA UL EAC
Standards	EN/IEC 60950-1 UL 508 EN/IEC 62314 CSA C22.2 No 14-13

Offer Sustainability

Sustainable offer status	Green Premium product
RoHS (date code: YYWW)	Compliant - since 1522 - Schneider Electric declaration of conformity Schneider Electric declaration of conformity
REACH	Reference not containing SVHC above the threshold Reference not containing SVHC above the threshold
Product environmental profile	Available Product Environmental Profile
Product end of life instructions	Available End of Life Information

Dimensions

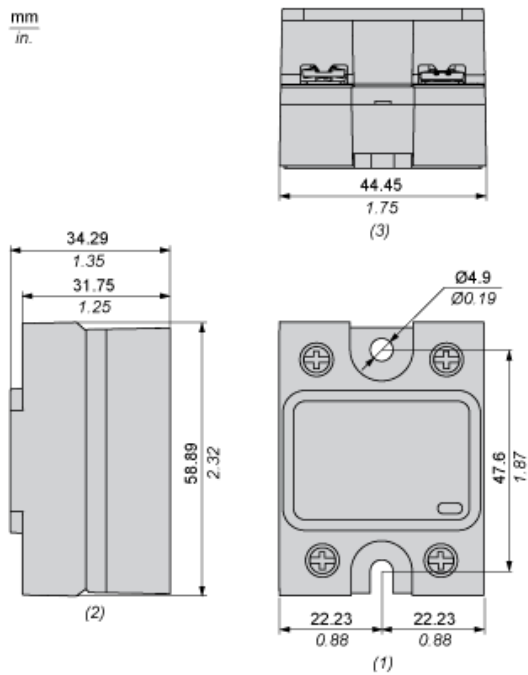

- (1) Front view
- (2) Side view
- (3) Bottom view

Derating Curves

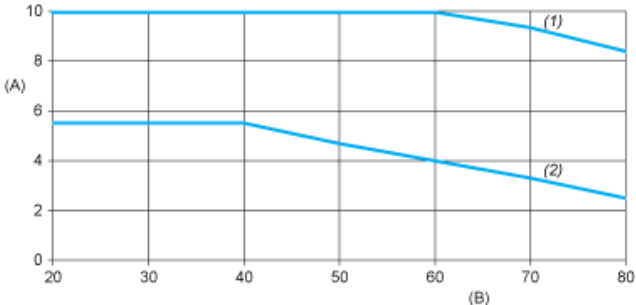

- A : Load Current (Arms)
- B : Ambient Temperature (°C)
- (1) For Heatsink SSRHP25
- (2) No Heatsink